

Atlas Copco

Oil-injected Rotary Screw Compressors
Variable Speed Drive+ (7-15 kW/10-20 hp)



- ▶ Extreme savings
- ▶ No idling time
- ▶ Silent operation
- ▶ Small footprint

Sustainable Productivity

Atlas Copco



The new revolutionary compressor from Atlas Copco

With its innovative vertical design, Atlas Copco's GA 7-15 VSD+ brings a game-changing revolution in the compressor industry. It offers Variable Speed Drive as standard, a compact motor and footprint thanks to its in-house design and iPM (Permanent Magnet) technology. The GA 7-15 VSD+ reduces energy consumption by on average 50%, with uptimes assured even in the harshest operational conditions. The GA 7-15 VSD+ is the air compressor of the future, designed in-house by Atlas Copco. It will set a new standard for years to come, positioning Atlas Copco as a leader in the compressed air industry.



EFFICIENT

- On average 20% lower Specific Energy Requirement (SER) than the current GA VSD models. Eco-efficient VSD+ reduces energy consumption by on average 50% compared to the current idling models.
- On top of energy savings, Free Air Delivery (FAD) increase of up to 12% over the range.
- Efficient fan motor (ERP 2015) reduces electricity consumption and noise levels.
- Highest motor efficiency (iPM), up to 94.5%, outperforming IE3 efficiency levels.

RELIABLE

- Low maintenance: fewer components, increased uptime.
- Worry-free: the GA 7-15 VSD+ has been extensively field-tested over three years.
- Based on unique combination of proven technologies and existing components, optimally brought together by Atlas Copco's unique experience and know-how.



SMART

- Elegant and revolutionary design.
- Frequency-controlled operation as standard (VSD+), integrated dryer available.
- Fewer components & very few options: impressive list of standard features.
- Ecological design, efficient material usage.



Small compressor, big ideas

INNOVATIVE VERTICAL DESIGN

Atlas Copco has turned the compressed air industry on its head by redesigning the conventional layout of a typical air compressor. Instead of the normal space-taking horizontal design, the new GA 7-15 VSD⁺ has an upright, vertical, low footprint layout. This saves valuable floor and work space, eases maintenance access, accelerates manufacturing time, and reduces the total cost of ownership for all customers.

COMPACT

- Extremely small footprint (610 x 630 mm).
- Clever design allows the GA 7-15 VSD⁺ to be placed against a wall.
- Robust: motor is oil-cooled; element rotor and motor have the same axis.
- Drive train: direct connection between element and motor.
- Very low noise level, with separate compartments for drive train and cooling.

Inside the innovative GA 7-15 VSD⁺

The GA 7-15 VSD⁺ is packed with innovative features that increase its efficiency, cut its energy consumption, lower its noise levels, and reduce its operating costs. In addition, it meets or even exceeds all currently applicable standards.



DRIVE TRAIN

1

Interior Permanent Magnet (IPM) motor

- Very high efficiency: exceeds IE3; 94.5%.
- Compact, customized design for optimal cooling by oil.
- Designed in-house in Belgium.
- IP66 vs. IP55.
- No cooling air flow required.
- Oil-lubricated motor bearing: no (re)grease(ing), increased uptime.

2

Element

- Made by Atlas Copco.
- Robust and silent.

3

Direct drive

- Vertical design, fewer parts.
- Oil-cooled, pressure-tight.
- No gears or belts, no shaft seal.
- Compact: footprint down 60%.





4

Innovative fan

- Based on the newest technologies.
- In compliance with ERP2015 efficiency.
- Low noise levels.

5

Robust oil filter/separator

- Integrated bypass valve with the oil filter.
- Easy maintenance.

6

Electronic no-loss water drain

- Included as standard.
- Efficient removal of condensate without loss of compressed air.
- Manual integrated bypass for effective condensate removal in case of power failure.

7

Elektronikon® controller

- Integrated smart algorithms reduce system pressure and energy consumption.
- Warning indications, maintenance scheduling and online status visualization.
- Graphic display of key parameters (day, week, month) and 32 language settings.

9

9

VSD+ cubicle

- VSD+ superior to idling machines.
- Electrical components remain cool, enhancing lifetime of components.
- Dedicated drive for iPM technology motors.
- 5% DC choke as standard.
- Heat dissipation of inverter in separate compartment.

6

5



8

Inlet valve

- No inlet arrestor.
- No blow off losses.
- Maintenance free.



Atlas Copco's GA Variable Speed Drive+ (VSD+) technology closely follows the air demand by automatically adjusting the motor speed. Combined with the innovative design of the iPM (Permanent Magnet) motor, this results in average energy savings of 50% and an average cut of 37% in the lifecycle cost of a compressor. VSD+ works with permanent, in-house designed magnet motors.

WHY ATLAS COPCO VARIABLE SPEED DRIVE+ TECHNOLOGY?

- On average 50% energy savings with an extensive flow range (20-100%).
- Integrated Elektronikon® Graphic controller controls the motor speed and high efficiency frequency inverter.
- No wasted idling times or blow-off losses during operation.
- Compressor can start/stop under full system pressure without the need to unload with special VSD+ motor.
- Eliminates peak current penalty during start-up.
- Minimizes system leakage due to a lower system pressure.
- EMC Compliance to directives (2004/108/EG).

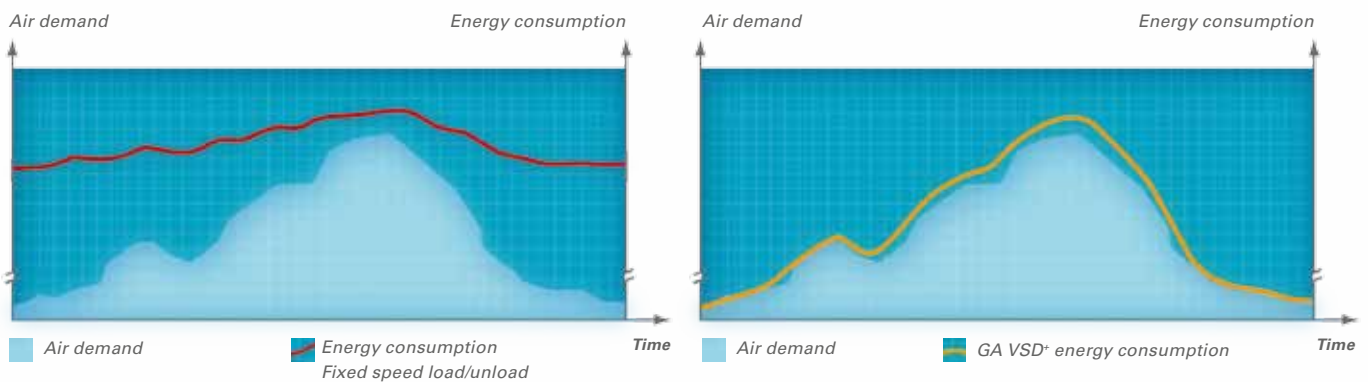

In almost every production environment, air demand fluctuates depending on different factors such as the time of the day, week or even month. Extensive measurements and studies of compressed air demand profiles show that many compressors have substantial variations in air demand.

Excellence in integrated air quality

Untreated compressed air contains moisture and aerosols which increase the risk of corrosion and compressed air system leaks. This can result in a damaged air system and contaminated end product. Maintenance costs can far exceed air treatment costs. Our compressors provide the clean, dry air that improves your system's reliability, avoids costly downtime and production delays, and safeguards the quality of your products.

SAVE MONEY AND THE ENVIRONMENT

Avoid risk of corrosion and system leaks, and ensure the effective safe disposal of untreated condensate – all within ISO 14001 standards.



ON AVERAGE 50% ENERGY SAVINGS WITH NEWLY DESIGNED INTEGRATED DRYERS

1. Pressure dew point of 3°C (100% relative humidity at 20°C).
2. Unique Saver Cycle Control, with ambient temperature sensor and based on dryer load and relative humidity of compressed air, saves energy at partial load.
3. Heat exchanger cross-flow technology with low pressure drop.
4. Zero waste of compressed air thanks to no-loss condensate drain.
5. Reduced operating costs.
6. Environmentally-friendly characteristics; zero ozone depletion.
7. Global warming potential has been reduced significantly by an average of 50% by reducing the amount of refrigerant in the new dryer.

ENERGY-SAVING CONTRIBUTORS



Technical specifications

COMPRESSOR TYPE	Maximum working pressure WorkPlace		Capacity FAD* min-max			Installed motor power		Noise level**	Weight Work-Place	Weight Work-Place Full Feature
	bar(e)	psig	l/s	m³/h	m³/h	kW	hp	dB(A)	kg	kg
GA 7 VSD+	5.5	80	7.2-21.9	25.9-78.8	15.2-46.4	7.5	10	62	193	277
	7	102	7.0-21.7	25.2-78.1	14.8-46.0	7.5	10	62	193	277
	9.5	138	6.8-18.0	24.5-64.8	14.4-38.1	7.5	10	62	193	277
	12.5	181	7.3-14.2	26.3-51.12	15.5-30.1	7.5	10	62	193	277
GA 11 VSD+	5.5	80	7.3-32.9	26.3-118.4	15.5-69.7	11	15	63	196	280
	7	102	7.3-32.5	26.3-117.0	15.5-68.8	11	15	63	196	280
	9.5	138	7.0-27.2	25.2-97.9	14.8-57.6	11	15	63	196	280
	12.5	181	7.6-23.5	27.4-84.6	16.1-49.8	11	15	63	196	280
GA 15 VSD+	5.5	80	7.2-42.3	25.9-152.3	15.2-89.6	15	20	64	199	288
	7	102	7.1-41.8	25.6-150.5	15.0-88.6	15	20	64	199	288
	9.5	138	6.8-35.5	24.5-127.8	14.4-75.2	15	20	64	199	288
	12.5	181	7.3-27.9	26.3-100.4	15.5-59.1	15	20	64	199	288

* Unit performance measured according ISO 1217 ed. 4 2009, annex E, latest edition.
 ** Mean noise level measured at a distance of 1 m according to ISO 2151: 2004 using ISO 9614/2 (sound intensity method); tolerance 3 dB(A).

Reference conditions:

- Absolute inlet pressure 1 bar (14.5 psi).
- Intake air temperature 20°C, 68°F

FAD is measured at the following effective working pressures:

- 5.5 bar(e)
- 7 bar(e)
- 9.5 bar(e)
- 12.5 bar(e)

Maximum working pressure:

- 13 bar(e) (188 psig)

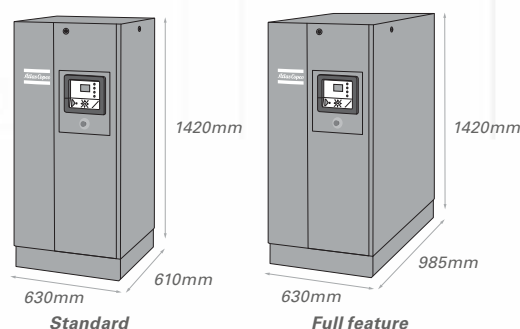

FLOW CHART GA VSD+ FF

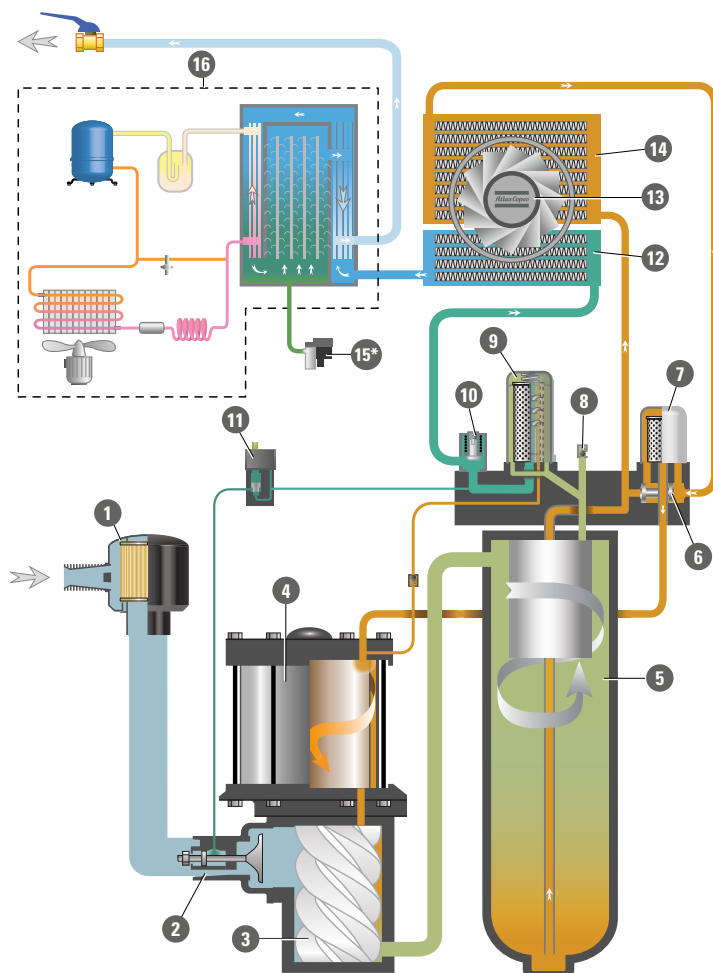

- 1 Inlet filter
 - 2 Sentinel valve
 - 3 Screw element
 - 4 iPM
 - 5 Air/oil vessel
 - 6 Thermostatic bypass valve
 - 7 Oil filter
 - 8 Safety valve
 - 9 Oil separator
 - 10 Minimum pressure valve
 - 11 Solenoid valve
 - 12 After cooler
 - 13 Fan
 - 14 Oil cooler
 - 15 Electronic drain (* mounted on after cooler on models without dryer)
 - 16 Dryer
-
- Intake air
 - Air/oil mixture
 - Oil
 - Wet compressed air
 - Condensate
 - Dry compressed air

VSD+ for 50% average energy savings*

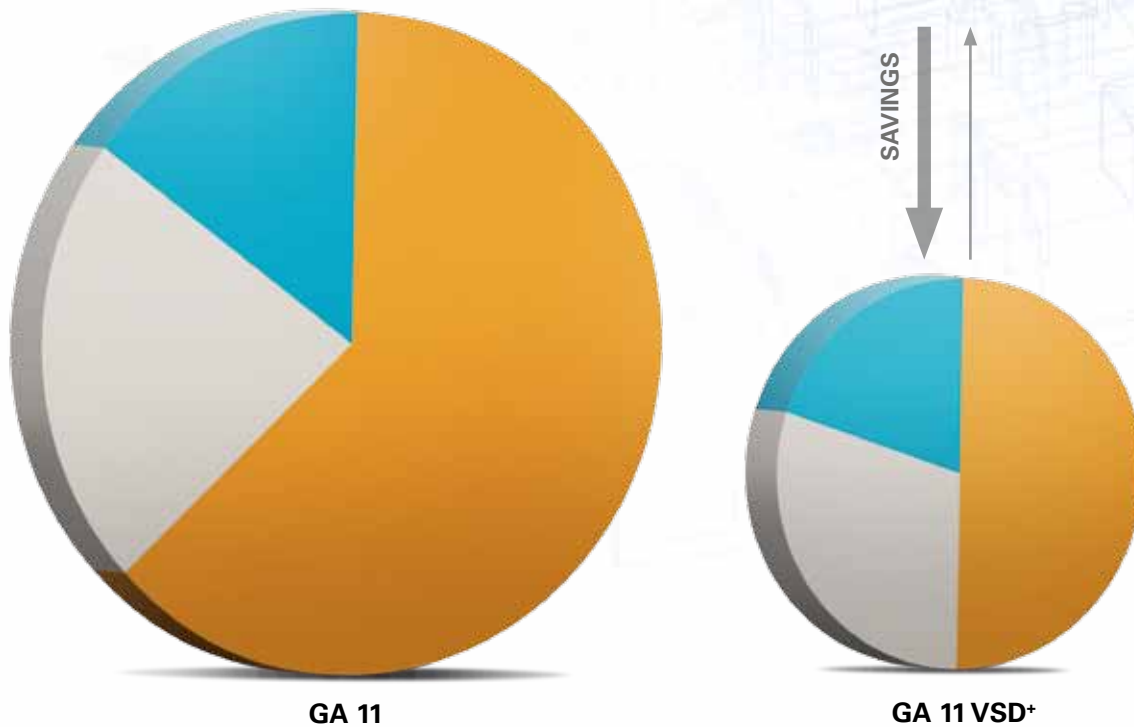

Energy Investment Maintenance

* Based on measurement performed by an independent energy audit agency.

A STEP AHEAD IN MONITORING AND CONTROLS

Dual pressure set point

Most production processes create fluctuating demands which, in turn, can create energy waste in low use periods. Using the Elektronikon®, you can manually or automatically create two different system pressure bands to optimize energy use and reduce costs.

Week timer

An on-board clock enables timers to be set up to support any working scheme – per day, per week, or completely customizable to your specific situation and needs.



Integrated Saver Cycles

Fan Saver Cycle reduces the energy consumption by switching off the fan in light load applications. Using an ambient sensor to monitor the required dew point suppression, the Elektronikon® starts and stops the dryer, minimizing energy use.



Driven by innovation

With more than 140 years of innovation and experience, Atlas Copco will deliver the products and services to help maximize your company's efficiency and productivity. As an industry leader, we are dedicated to offering high air quality at the lowest possible cost of ownership. Through continuous innovation, we strive to safeguard your bottom line and bring you peace of mind.



Building on interaction

As part of our long-term relationship with our customers, we have accumulated extensive knowledge of a wide diversity of processes, needs and objectives. This gives us the flexibility to adapt and efficiently produce customized compressed air solutions that meet and exceed your expectations.



A committed business partner

With a presence in over 170 countries, we will deliver high-quality customer service anywhere, anytime. Our highly skilled technicians are available 24/7 and are supported by an efficient logistics organization, ensuring fast delivery of genuine spare parts when you need them. We are committed to providing the best possible know-how and technology to help your company produce, grow, and succeed. With Atlas Copco you can rest assured that your superior productivity is our first concern!



www.atlascopco.com